

ELECTROMECHANICAL OPERATOR FOR GARAGE DOORS

FENIX

_24Vdc Encoder



- _ Smart. Self learning of the open/close travel and slow down distances
- _ Safety. Obstacle detection
- _ Easy to install
- _ Quiet in operation

ERREKA





FENIX KITS

FENIX 1

FE80RES Operator (Reson receiver

incorporated) (1 pc.)

Chain rail AFE01 (1 pc.)

Two button transmitter LU02 (2 pcs.)

* Kit example. Other kit combinations on request.

Other accesories

Keypads, electrolocks, flashing lamps, rubber edges, magnetic loop metal detectors, traffic lights,...



KIT FENIX 1



FE80RES
1 pc.



LUNA
2 pcs.



AFE01
1 pc.

TECHNICAL DATA

	FE80RES
Power supply	230 / 50 V
Absorbed power	0,25 Kw
Motor voltage	24 Vdc
Protection class	20 IP
Torque max.	800 N
Operating temperature	-20 / +60 °C
Operator weight without rail	4,5 kg
Use	Residencial

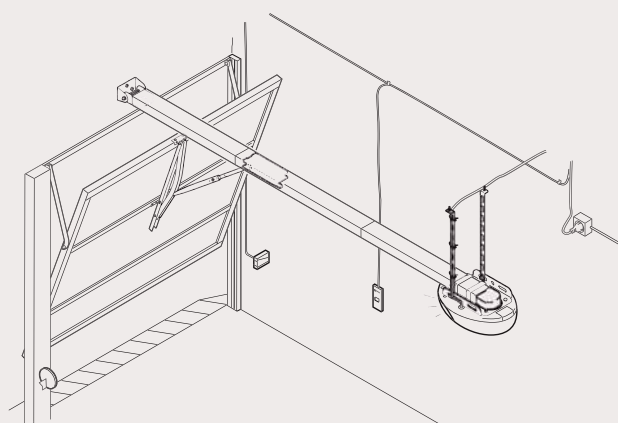

FENIX UP&OVER DOORS

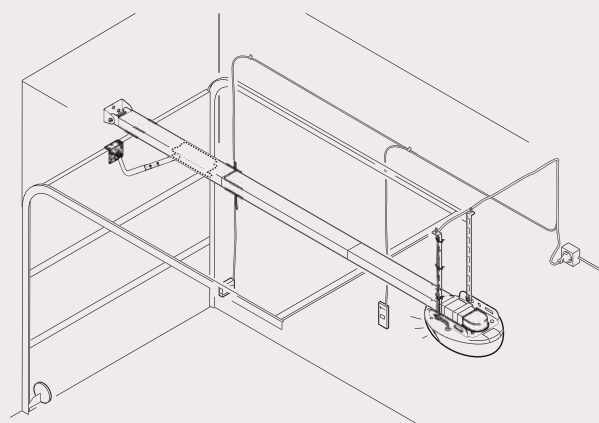

FENIX SECTIONAL DOORS

